

CUSTOMER TERMINAL	RoHS	LEAD(Pb)-FREE
Sn96%, Ag4%	Yes	Yes

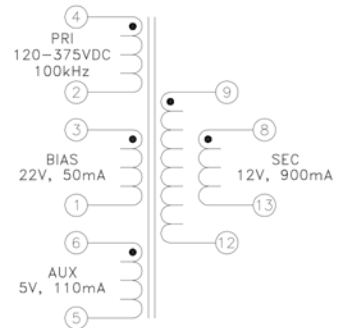

Customer to tie terminals 8&9 and 12&13 on PC board.

Application of the transformer allows for the leadwires between terminals 8&9 and 12&13 to solder bridge.

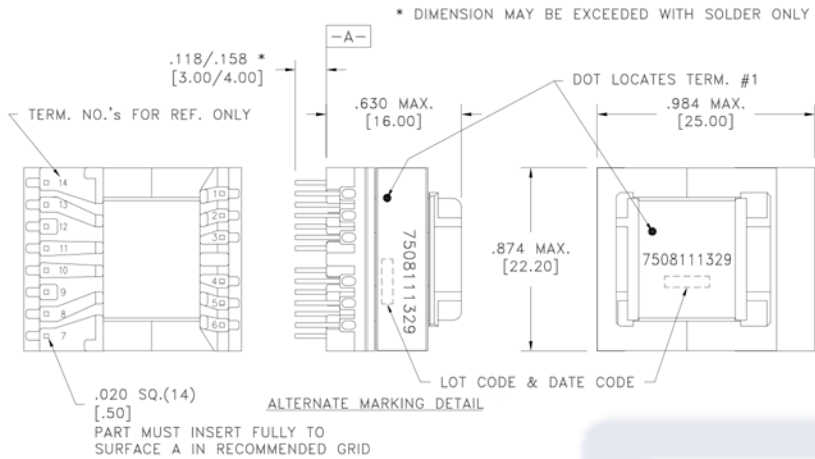
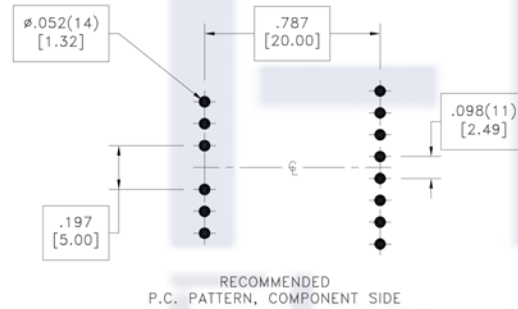

ELECTRICAL SPECIFICATIONS @ 25°C unless otherwise noted:

PARAMETER	TEST CONDITIONS	VALUE
D.C. RESISTANCE	4-2 @20°C	0.285 ohms ±10%
D.C. RESISTANCE	3-1 @20°C	0.170 ohms ±10%
D.C. RESISTANCE	6-5 @20°C	0.055 ohms ±10%
D.C. RESISTANCE	9-13, tie(8+9, 12+13), @20°C	0.016 ohms ±20%
INDUCTANCE	4-2 10kHz, 100mVAC, Ls	400.0uH ±10%
SATURATION CURRENT	4-2 20% rolloff from initial	700mA
LEAKAGE INDUCTANCE	4-2 tie(1+3, 5+6, 8+9+12+13), 100kHz, 100mVAC, Ls	2.0uH typ., 4.0uH max.
DIELECTRIC	1-13 tie(2+3, 4+5, 8+9), 3750VAC, 1 second	3000VAC, 1 minute
DIELECTRIC	1-4 625VAC, 1 second	-
DIELECTRIC	1-6 625VAC, 1 second	-
URNS RATIO	(4-2):(9-13), tie(8+9, 12+13)	6:1, ±1%
URNS RATIO	(4-2):(3-1)	3.27:1, ±1%
URNS RATIO	(4-2):(6-5)	12:1, ±1%

GENERAL SPECIFICATIONS:

OPERATING TEMPERATURE RANGE: -40°C to +125°C including temp rise.

Designed to comply with the following requirements as defined by IEC60950-1, EN60950-1, UL60950-1/CSA60950-1 and AS/NZS60950.1:
 - Reinforced insulation for a primary circuit at a working voltage of 265Vrms, 400Vpeak, Overvoltage Category II.

Wire insulation & RoHS status not affected by wire color.
 Wire insulation color may vary depending on availability.

REV.	DATE	Packaging Specifications Method: Tray PKG-0736		Tolerances unless otherwise specified: Angles: ±1° Fractions: ±1/64 Decimals: ±.005 [.13] Footprint: ±.001 [.03]	DRAWING TITLE TRANSFORMER	PART NO. FKS7508111329
6A	9/15		CONVENTION PLACEMENT	This drawing is dual dimensioned. Dimensions in brackets are in millimeters.	eiSos p/n: FKS7508111329	compliant RoHS SPECIFICATION SHEET 1 OF 1