

CUSTOMER TERMINAL	RoHS	LEAD(Pb)-FREE
Sn96%, Ag4%	Yes	Yes

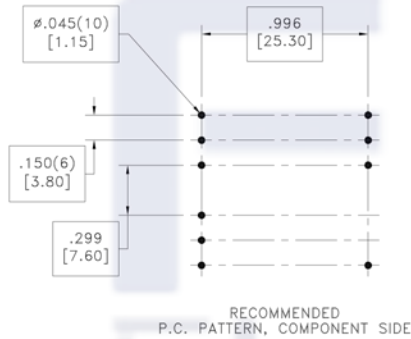

PART MUST INSERT FULLY TO SURFACE A IN RECOMMENDED GRID

* DIMENSION MAY BE EXCEEDED WITH SOLDER ONLY

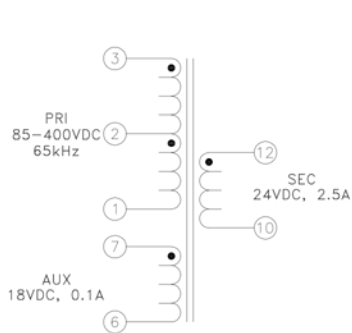
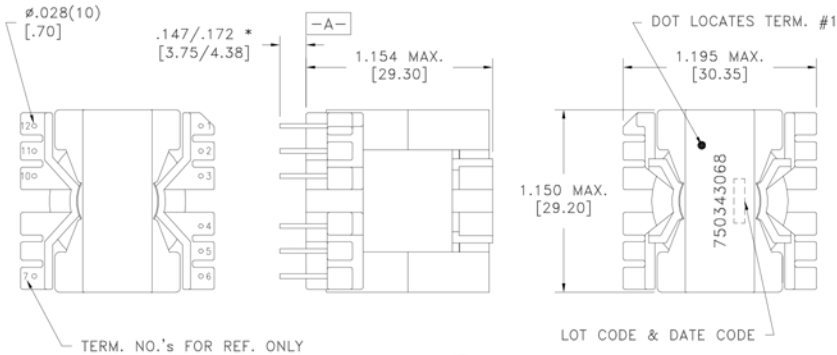

ELECTRICAL SPECIFICATIONS @ 25°C unless otherwise noted:

PARAMETER	TEST CONDITIONS	VALUE
D.C. RESISTANCE	3-1 @20°C	0.185 ohms max.
D.C. RESISTANCE	7-6 @20°C	0.163 ohms max.
D.C. RESISTANCE	12-10 @20°C	0.021 ohms max.
INDUCTANCE	3-1 50kHz, 100mVAC, Ls	230.0uH ±10%
SATURATION CURRENT	3-1 20% rolloff from initial	4.4A
LEAKAGE INDUCTANCE	3-1 tie(6+7+10+12), 100kHz, 100mVAC, Ls	3.5uH max.
DIELECTRIC	1-12 tie(3+6), 3750VAC, 1 second	-
DIELECTRIC	12-Core 3750VAC, 1 second	-
URNS RATIO	(3-1):(7-6)	4.67:1, ±2%
URNS RATIO	(3-1):(12-10)	3.89:1, ±2%

GENERAL SPECIFICATIONS:

OPERATING TEMPERATURE RANGE: -40°C to +125°C including temp rise.

Designed to comply with the following requirements as defined by IEC60950-1, EN60950-1, UL60950-1/CSA60950-1 and AS/NZS60950.1:
 - Reinforced insulation for a primary circuit at a working voltage of 400Vpeak, Overvoltage Category II.

Wire insulation & RoHS status not affected by wire color.
 Wire insulation color may vary depending on availability.

REV.	DATE	Packaging Specifications Method: Tray PKG-0807		Tolerances unless otherwise specified: Angles: ±1° Fractions: ±1/64 Decimals: ±.005 [0.13] Footprint: ±.001 [0.03]	DRAWING TITLE TRANSFORMER	PART NO. FKS750343068
6A	9/16		CONVENTION PLACEMENT	This drawing is dual dimensioned. Dimensions in brackets are in millimeters.	eiSos p/n: FKS750343068	compliant RoHS SPECIFICATION SHEET 1 OF 1